



Physics Education Program

Name: \_\_\_\_\_

Teacher: \_\_\_\_\_

School: \_\_\_\_\_

# Horizontal Accelerometer

*student activity*

## Key Ideas

Acceleration, Gravity, Resolving vectors

## Equipment

Stiff white cardboard  
 Small washer  
 Strong sewing elastic for wrist strap  
 Black string  
 Clear plastic (e.g. A4 sheet protector)  
 Sticky tape

Coloured pens  
 Protractor  
 Scissors  
 Compass with a sharp point

This activity should be completed before you visit Dreamworld.

### Standard Achieved: Scientific Techniques and Scientific Investigation

VHA	HA	SA	LA	VLA	Not Attempted
<ul style="list-style-type: none"> <li>identifies and applies risk management procedures</li> </ul>	<ul style="list-style-type: none"> <li>identifies and applies safety procedures</li> </ul>	<ul style="list-style-type: none"> <li>applies safety procedures</li> </ul>	<ul style="list-style-type: none"> <li>follows safe practices</li> </ul>	<ul style="list-style-type: none"> <li>follows safety instructions</li> </ul>	<ul style="list-style-type: none"> <li>not attempted</li> </ul>
<ul style="list-style-type: none"> <li>identifies relationships between trends and patterns in data and information</li> </ul>	<ul style="list-style-type: none"> <li>identifies trends and patterns in data and information</li> </ul>	<ul style="list-style-type: none"> <li>identifies obvious trends and patterns in data and information</li> </ul>	<ul style="list-style-type: none"> <li>identifies obvious patterns in data and information</li> </ul>	<ul style="list-style-type: none"> <li>records data and information</li> </ul>	<ul style="list-style-type: none"> <li>not attempted</li> </ul>

**Theory of Operation**

When at rest, the plumb bob (a washer in this case) hangs vertically, and the only acceleration experienced is that of gravity. Any horizontal acceleration will result in a deflection of the plumb bob at some angle. The magnitude of the angle is directly related to the horizontal and vertical accelerations experienced by the plumb bob, and is easily resolved using a simple force diagram as illustrated below.

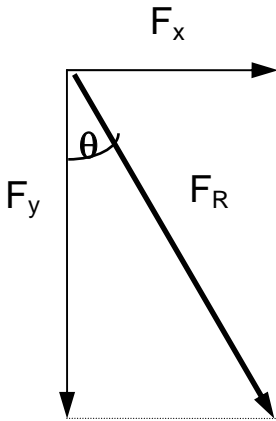

$$F_y = m g \quad \text{Equation 1}$$

$$F_x = m a \quad \text{Equation 2}$$

$$\tan \theta = \frac{F_x}{F_y}$$

substituting for  $F_y$  and  $F_x$ , we have:

$$\tan \theta = \frac{m a}{m g}$$

$$\theta = \tan^{-1} \left[ \frac{a}{g} \right] \quad \text{Equation 3}$$

Since the vertical component of  $F_r$  remains constant, the accelerometer scale can be calibrated to give a direct reading of acceleration by calculating the angles of  $\theta$  for various values of  $a$ .

Complete the following table of the values of  $\theta$  for various values of horizontal acceleration using equation 3. You will later mark these values of  $\theta$  directly onto your accelerometer in **gs**.

Use equation 3 with  $g = 9.8 \text{ ms}^{-2}$  to complete the following table for horizontal accelerations to calibrate your accelerometer

Acceleration ( $\text{ms}^{-2}$ )	Number of gs (g)	Angle $\theta$ (degrees)
4.90	0.5	26.6
7.35		
	1	
14.7		
29.40		
	4	

**Horizontal Accelerometer Assembly**

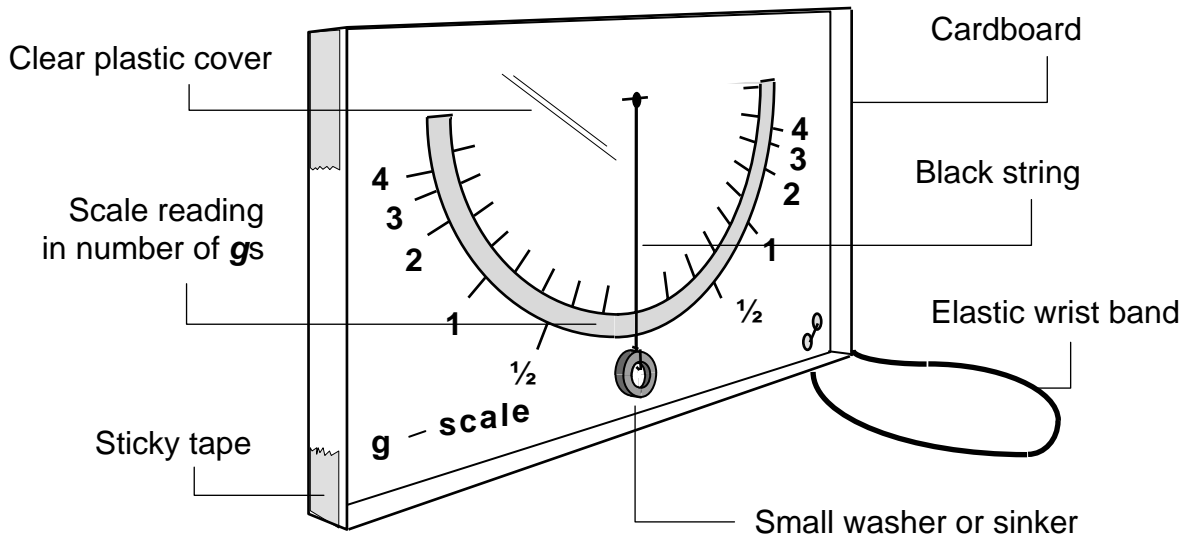

*A completed horizontal accelerometer*

Note: It is possible to convert a clinometer into a great accelerometer, simply by marking the values of the acceleration at the appropriate points.

**Assembly Instructions**

**Before you begin**

- Obtain all the materials and equipment required including the table calibration accelerometer
- Read right through the instructions before beginning

**Step 1  
Draw  
Protractor**

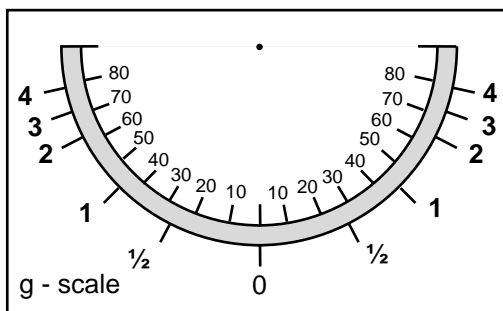

Trace the outline of a protractor onto a rectangular piece of cardboard. Mark angles in increments of 5° and label increments of 10°. Use a compass to draw a semi circle *outside* that of the traced protractor. On this second arc, mark and label the angles for the values of horizontal acceleration calculated previously.

**Step 2**

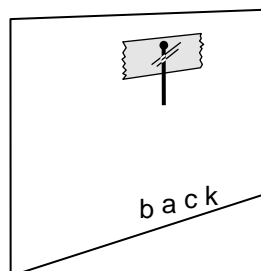
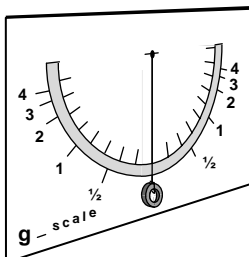

Pierce a hole for the plumb bob string at the compass point of the semi-circles. Insert the string and secure it with a knot and sticky tape over it as illustrated. Secure the washer on the other end so that it hangs above the bottom of the cardboard. Use several knots to prevent the washer becoming loose.

**Step 3**

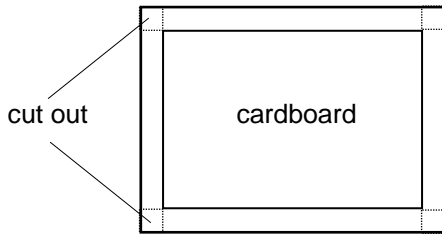

Cut another rectangular piece of cardboard the same size as the first, but with a 1 cm border to be folded up as illustrated. Cut all four squares out of the corners.

**Step 4**

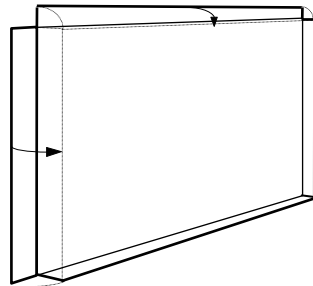

Fold up the sides and secure them into place using sticky tape to make a shallow box.

**Step 5**

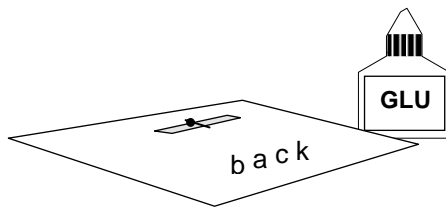

Apply PVA or other suitable glue to the back of the cardboard protractor and position it in the box you made in step 4. Press firmly to ensure good adhesion. Leave to dry for five minutes while completing Step 6.

**Step 6**

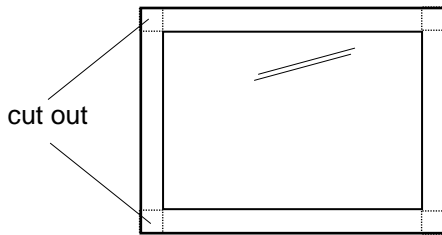

Cut a piece of strong clear plastic (such as from an A4 sheet protector) in the same shape as the cardboard in Step 4, again removing the corners. This will make a clear cover for your accelerometer.

**Step 7**

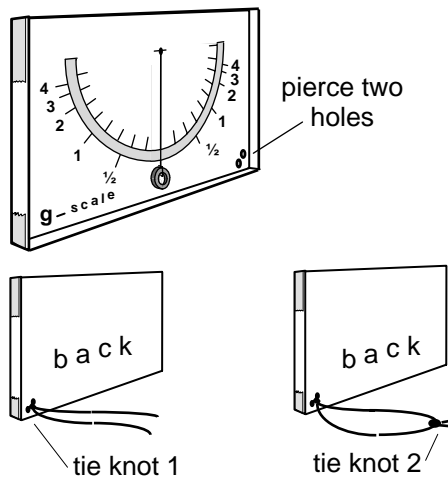

Use the point of a compass to pierce two holes in the bottom corner of the accelerometer. Thread braided elastic through the holes as illustrated and tie a knot to secure it in place. Tie a second knot to form a loop for your wrist.

**Step 8** add clear plastic

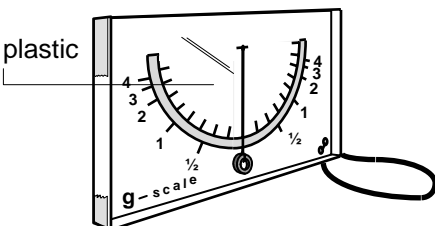

Cover the front of the accelerometer with the plastic you prepared in Step 6. Use sticky tape to secure the plastic in place.

Your accelerometer is complete.

**Safety Tests Conducted at Dreamworld**

The following tests will be conducted on each of your accelerometers upon arrival at Dreamworld, so it is important that you try them first. All three tests need to be passed in order for approval to use the accelerometer within Dreamworld. Accelerometers that meet the requirements receive an approval sticker to notify ride attendants. Only approved accelerometers will be allowed to ride.

**Test 1 Wrist and Elbow Strap Inspection**

- The wrist straps must secure the accelerometer firmly to the rider so that it cannot swing away or be dropped if released.

**Test 2 Vigorous Shaking**

- The accelerometer must be able to withstand vigorous shaking. The washer must not break through the plastic cover sheet during shaking.

**Test 3 Drop Test**

- The accelerometer must be able to withstand a drop from a height of 2 metres onto a carpeted floor without breakage or the washer breaking through the plastic cover sheet.